



Inclinometer

HIT 1500

CANopen Safety

Increased functional safety

MEMS technology

Motion-compensated

Accuracy 0.1 ° typ.

CANopen
safety easy to use

CE **US**

E1

Functional Safety
PL d
SIL 2

Features

- Motion compensated inclination measurement via sensor fusion
- High signal dynamics
- High degree of accuracy
- Temperature compensation
- Diverse signal output
 - Inclination static
 - Inclination motion compensated
 - Acceleration: 3 axes
 - Speed rate in 3 axes
- Functional safety acc. to EN 61508 SIL 2
ISO 13849 PL d
- Functionally safe structure according to category 2 or 3 (ISO 13849) available
- E1 approved for road vehicles

Description

The HIT 1500 measuring systems are single or double axis measuring systems for the detection of the inclination with regards to their horizontal plane. The HIT 1500 family has been especially developed for the detection of the inclination inside of dynamic systems.

The inclination signal is calculated in quasi-static condition, based on a 3 axis acceleration sensor using MEMS technology (Micro-Electro-Mechanical System).

A motion compensated inclination signal is calculated by fusing the two physically independent signals of acceleration and gyro.

In addition to the inclination signals, the acceleration and gyro values are also available in all 3 spatial axes. The application developer is provided with a higher degree of freedom which can be used for the optimisation of control processes in the machine control.

The inclination sensor versions for applications with increased functional safety are designed according to SIL2 (IEC 61508) and PL d (ISO 13849). Two safety architectures are available: Category 2 (ISO 13849) or 1oo1 (EN 61508) and Category 3 or 1oo2.

A safe transmission of the measured values is ensured by the CANopen Safety Protocol. The following signals can be transmitted safely: static inclination within 2 spatial axes with status word, the acceleration values as well as the gyro, each within the 3 spatial axes.

Application fields

All mobile working machines with requirements especially for dynamic position or inclination detection are used.

Based on the safe static inclination signal, functions with increased requirements on functional safety, such as tilt protection, may be carried out.

Thus, the HIT 1500 provides excellent dynamic characteristics and is therefore particularly suited for the active orientation, stabilisation and control of the inclination in mobile machines such as boom lifts and work platforms, cranes and mobile cranes, construction and drilling devices, agricultural and municipal machines, etc.

Especially for the use in public traffic vehicles, HIT 1500 is approved for road vehicles according to ECE type approval.

Technical details

Input data inclination			
Axes		1/2	
Measuring range (primary axis; "longitudinal")		° ±180 (±15 / ±60 / ±120 available)	
Measuring range (secondary; "lateral")		° ±90 (±15 / ±60 available)	
Resolution		° 0.01	
Temperature coefficient (-20 to +60 °C)		°/10K	< 0.03 typ. (RMS) 0.06 max.
Long term stability		°/1000h	< 0.1 typ. (RMS) 0.15 max.
Static [functionally safe]¹⁾	Dynamic performance	Hz	2 (-3 dB)
	Accuracy	°	< 0.1 typ. (RMS) 0.2 max.
	Repeatability	°	< 0.05 typ. (RMS) 0.1 max.
Motion-compensated	Dynamic performance	Hz	50 (-3 dB)
	Update rate	Hz	200
Input data acceleration (ACC) Functional safety			
Axes		3	
Measuring range		m/s ²	±30 in 3 axes
Resolution		m/s ²	0.01
Cutoff frequency		Hz	50 (-3 dB)
Accuracy		m/s ²	< 0.02 typ. (RMS) 0.04 max.
Temperature coefficient (-20 to +60 °C)		(m/s ²)/10 K	< 0.005 typ. (RMS) 0.01 max.
Long-term stability		(m/s ²)/1000 h	< 0.01 typ. (RMS) 0.02 max.
Input data gyro (GYRO) Functional safety			
Axes		3	
Measuring range		°/s	± 250 in 3 axes
Resolution		°/s	0.01
Cutoff frequency		Hz	50 (-3 dB)
Noise density (band width 100 Hz)		(°/s)/Hz ^{1/2}	0.03
Accuracy		°/s	< 0.4 typ. (RMS) 1.0 max.
Temperature coefficient (-20 to +60 °C)		(°/s)/10K	< 0.03 typ. (RMS) 0.1 max.
Long-term stability		(°/s)/1000 h	< 0.05 typ. (RMS) 0.2 max.
Output data			
Output signal		CANopen safety Protocol	
Environmental conditions / Approvals / Tests			
Compensated temperature range		°C	-20..+60
Operating temperature range		°C	-40..+85
Storage temperature range		°C	-40..+85
Operating height		mNN	0..3000
EMC		EN 61000-6-1 / 2 / 3 / 4 (see declaration of conformity)	
CE conformity		Available	
UL approval ²⁾		Available	
E approval		Available acc. to UNECE 10	
Vibration resistance acc. to DIN EN 60068-2-6 at 10..500 Hz		5 g (criterion B)	
Shock resistance acc. to DIN EN 60068-2-27		20 g, 11 ms half sine (criterion B)	
Protection type ³⁾		acc. to DIN EN 60529 acc. to ISO 20653	IP66, IP67, IP69 IP6K9K
Safety-related data			
Performance Level	Based on PL	DIN EN ISO 13849-1:2015	
	PL	d	
	Architecture	Category 2 or 3	
Safety Integrity Level	Based on SIL	DIN EN 61508:2010	
	SIL	2	
	Architecture	1oo1 / 1oo2	
Other data			
Supply voltage when applied acc. to UL specifications -limited energy- acc. to 9.4 UL 61010; Class 2 UL 1310/1585; LPS UL 60950		V DC	9..36 9..35 for wet locations
Residual ripple of supply voltage		%	< 5
Power consumption		W	Cat. 2: < 1 Cat. 3: < 2
Housing material		Aluminium, anodised	
Weight		g	-400

Protocol data for CANopen Safety

Communication Profile	CiA 301 V4.2
Layer Setting Services and Protocol	CiA 305 V2.2
Device Profile	CiA 410 V1.3
Functional safety communication	EN 50325-5:2010
Bit rates	10 kbit..1 Mbit acc. to CiA 305 V2.2
Node ID / Bit rate	adjustable via Manufacturer Specific Profile & LSS
Default settings	Bit rate: 250 kbit/s Node ID: 1

Note: Reverse polarity protection of the supply voltage, excess voltage, override and short circuit protection are provided.

- 1) Observe chapter *Product description* of the operating instructions (BA). Download of the operating instructions under www.hydac.com (Enter „HIT 1500„ in the search box)
- 2) Environmental conditions acc. to 1.4.2 UL 61010-1; C22.2 no. 61010-1
- 3) With mounted mating connector in corresponding protection type

Dimensions

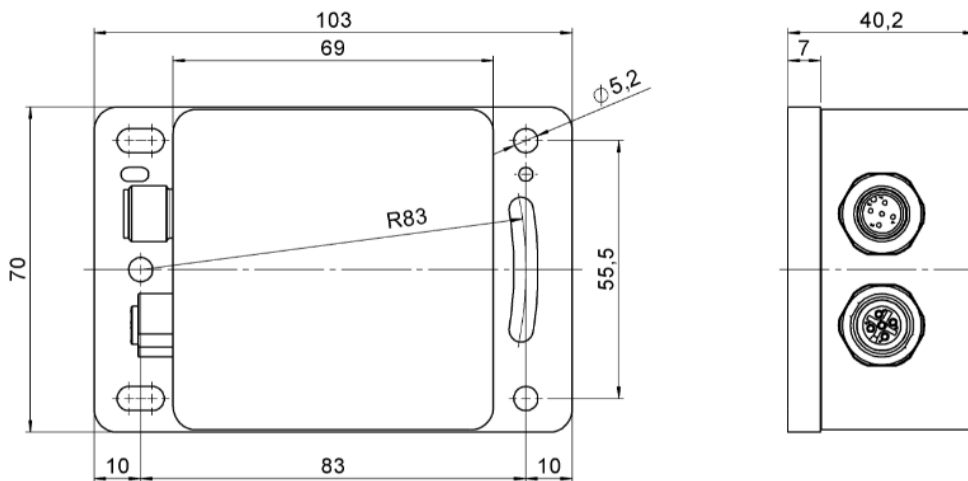

Coordinate system and turning direction

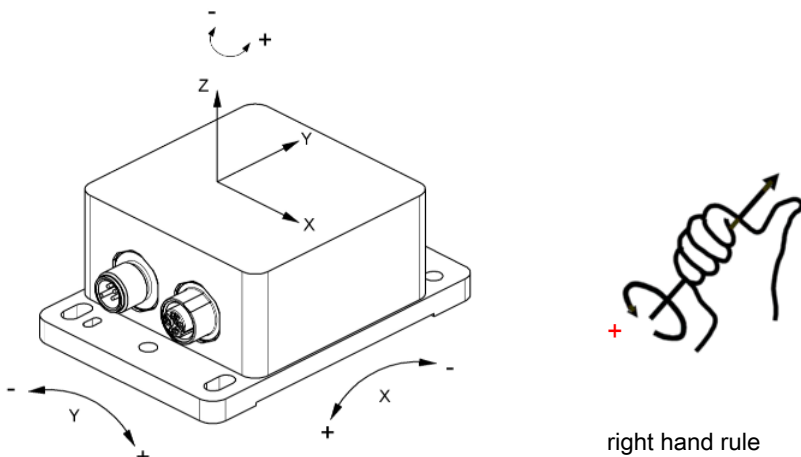

Pin connections

Plug M 12x1, 5 pole	Socket M12x1, 5 pole	Pin	Output signal: F1X	
			Signal	Description
		1	CAN_SHLD	Shield/housing
		2	CAN_V+	External supply +
		3	CAN_GND	Ground / 0 V / V -
		4	CAN_H	Bus line dominant high
		5	CAN_L	Bus line dominant low

Model code

H I T 1 5 0 8 - F 1 3 - X - X X X - X - X X - X - X X X X - X - 0 0 0

Motion compensation

5 = Included

Electrical connection

8 = Plug M12X1, 5 pole (mating connector not included)

Output signal

F13 = CANopen Safety

Primary inclination axis (longitudinal; slope long)

X / Y / Z

Measuring range rotation about primary axis in °

180 [015; 060; 120] optional

Secondary inclination axis (slope lateral)

X / Y / Z / 0 (0 = not available)

Measuring range rotation about secondary axis in °

90 [15; 60; 00 (00 = axis not available)] optional

Additional CAN connector

0 = None

1 = Connector M12x1, 5 pole

Functional Safety

S2PD = SIL2 to EN 61508 and PLd to ISO 13849

Design Architecture

2 = Category 2 acc. to ISO 13849

3 = Category 3 acc. to ISO 13849

Modification Number

000 = Standard

Note

The information in this brochure relates to the operating conditions and applications described.
For applications and/or operating conditions not described please contact the relevant technical department.
Subject to technical modifications.

HYDAC ELECTRONIC GMBH

Hauptstrasse 27

D-66128 Saarbruecken

Phone: +49 (0)6897 509-1

Fax: +49 (0)6897 509-1726

Email: electronic@hydac.com

Website: www.hydac.com